

EXC-LED Grille screen

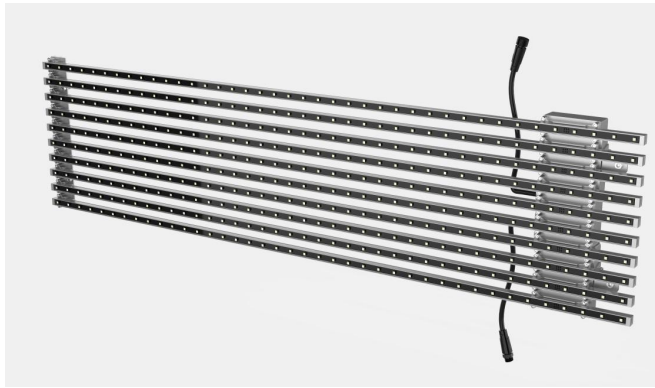

Application Environment:
Indoor
Outdoor

Description

LED Grid screen series products are a kind of LED grid screen with aluminum profile shell specially designed for outdoor landscape lighting by ecklet. The products are light and transparent, suitable for media advertising applications such as glass curtain wall, building exterior wall and outdoor large screen.

Features

- The New generation synchronous control system
- Low power consumption, high penetration design
- Light and ultra thin design with small wind load
- Modular, waterproof and detachable structure, convenient and fast maintenance
- No steel structure, front and back installation design
- Outdoor lightning protection and electrostatic discharge (ESD) protection design

Product specifications

Product model	GS2525A	GS2536A	GS2550A	GS5050A	GS3264A
LED light source	SMD3535 RGB	SMD3535 RGB	SMD3535 RGB	SMD3535 RGB	SMD3535 RGB
Pixel spacing	25*25.6mm	25*36.5mm	25*51.2 mm	50*51.2 mm	31.25*64mm
Resolving power	1600dot/m ²	1120dot/m ²	800dot/m ²	400dot/m ²	512dot/m ²
input voltage	DC36-48V	DC36-48V	DC36-48V	DC36-48V	DC36-48V
Max.power	480w/m ²	350w/m ²	240w/m ²	120w/m ²	160w/m ²
Grayscale	65536	65536	65536	65536	65536
refresh frequency	>1KHZ	>1KHZ	>1KHZ	>1KHZ	>1KHZ
Framing frequency	>18HZ	>18HZ	>18HZ	>18HZ	>18HZ
brightness	≥4800cd/m ²	≥3360cd/m ²	≥2400cd/m ²	≥1200cd/m ²	≥1536cd/m ²
visual angle	>120°	>120°	>120°	>120°	>120°
permeability	56%	>69%	>75%	>75%	>79%
Shell material	Aluminum	Aluminum	Aluminum	Aluminum	Aluminum
Unit direction	Horizontal	Horizontal	Horizontal	Horizontal	Horizontal
Standard unit size	1000x256mm	1000x256mm	1000x256mm	1000x256mm	1000x256mm
Resolution / unit	40x10	40x7	40x5	20x5	32x4
weight	14.4kg/m ²	11kg/m ²	8.76kg/m ²	8.76kg/m ²	7.64kg/m ²
Installation mode	Front&Back	Front&Back	Front&Back	Front&Back	Front&Back
Protection level	IP66	IP66	IP66	IP66	IP66

Physical Dimension

单位: mm Unit: mm

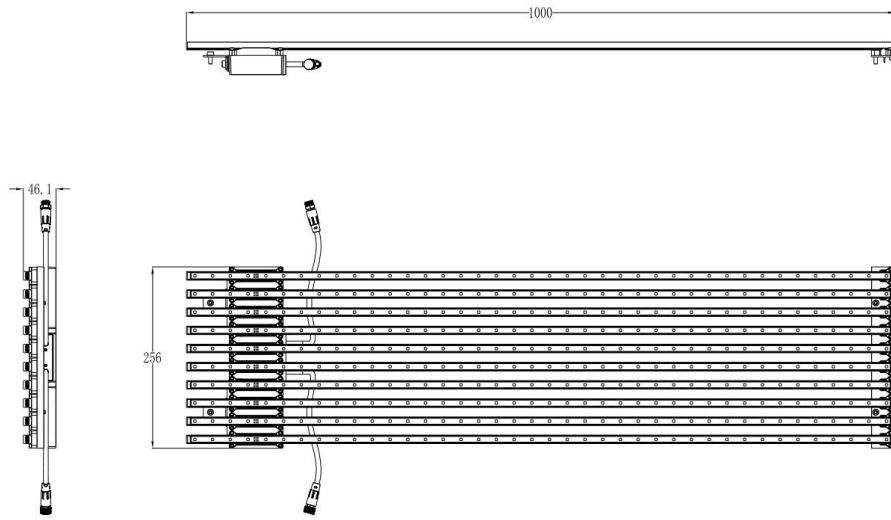

Product installation

Unit: mm

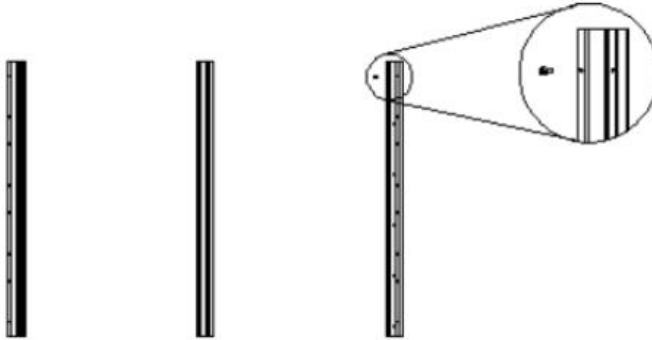

Tightly screw the Prefabricated profile

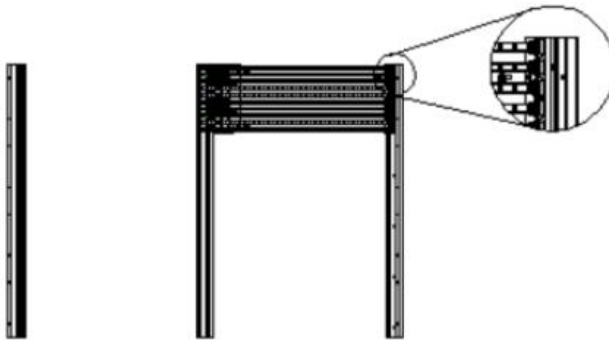

Use M4 Screw(4pcs) ,Fix the single grille unit on the prefabricated profile

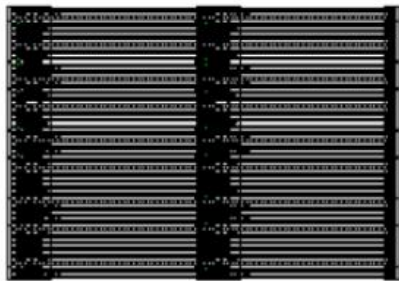

Fix the rest of the grille units as per left figure, sorted out all the wires in order